

DH-PFA162

Housing Bracket



Features

- Aesthetic design
- Material: aluminum
- Housing bracket
- Support three-axis rotation for housing installation

Technical Specifications

Model	DH-PFA162
General	
Material	Aluminum
Dimension (WxHxD)	115mmx115mmx98.8mm (4.53"x4.53"x3.89")
Weight	0.5kg(1.1lb)
Load Bearing	6.0kg(13.23lb)
Color	White
Operating Temperature	-40°C~+60°C(-40°F~+140°F)
Humidity	0~90% RH
Applicable Model	PFH610N/V/A series housing

Dimensions (mm/inch)

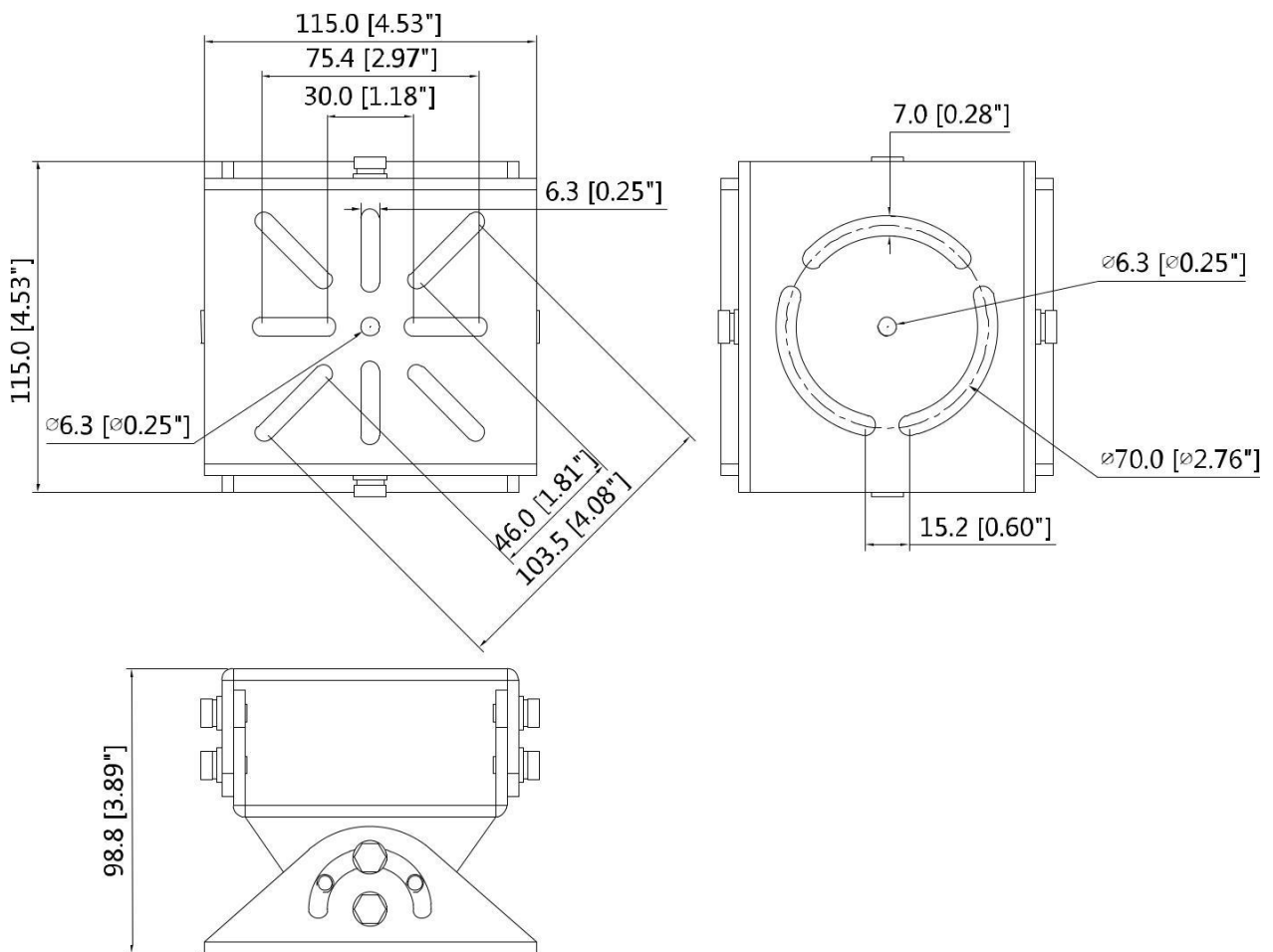

Application

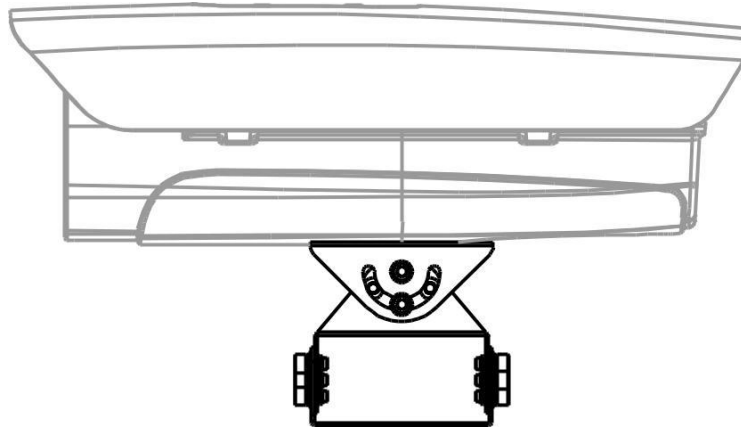

Package Information

- Housing bracket *1
- M6x14 screw *2
- 1/4-20x12UNC screw *2
- Wrench *1